

Powerful thanks to maintenance-free 3-phase AC drive motor

Compact due to extremely short chassis length

Outstanding driving stability

Multi-shift operation facilitated by sideways battery exit (optional)



EJE 116/118/120

Electric pedestrian pallet truck (1,600/1,800/2,000 kg)

The EJE Series 1 pallet trucks are a particularly economic means of loading and offloading HGVs as well as transporting pallets over short distances. The main advantage: Due to its short chassis length (L2) of just 494 mm (short version), the EJE can be manoeuvred in very restricted spaces.

The innovative 3-phase AC drive motor is another advantage. Its optimised efficiency ensures high speed and powerful acceleration – ideal for fast, efficient product throughput. In addition to its speed, it also offers long operating times: Batteries up to 250 Ah in combination with excellent energy management ensure long operating times. For operations lasting more than 1 shift, the battery can be removed laterally for quick battery replacement (optional for EJE 118/120).

The low-mounted long tiller ensures safe operation. They

maintain the adequate distance between the operator and the truck. Especially when cornering, the EJE 116 - 120 never gets too close to the operator. If space is at a premium, the crawl speed button makes travelling safe with the tiller in the upright position. A touch of the button is sufficient: The brake is released and activation of the travel switch automatically reduces the speed of travel. Particularly in confined spaces, the low battery height has its advantages. It provides even the shortest of operators with optimum visibility of the fork tips.

The re-designed multi-functional tiller arm is full of innovations: Sealed sensor system (IP 65) for maximum breakdown protection, rocker switches with contactless electronics for precise operation in any tiller position, ergonomically arranged switches.

EJE 116/118/120

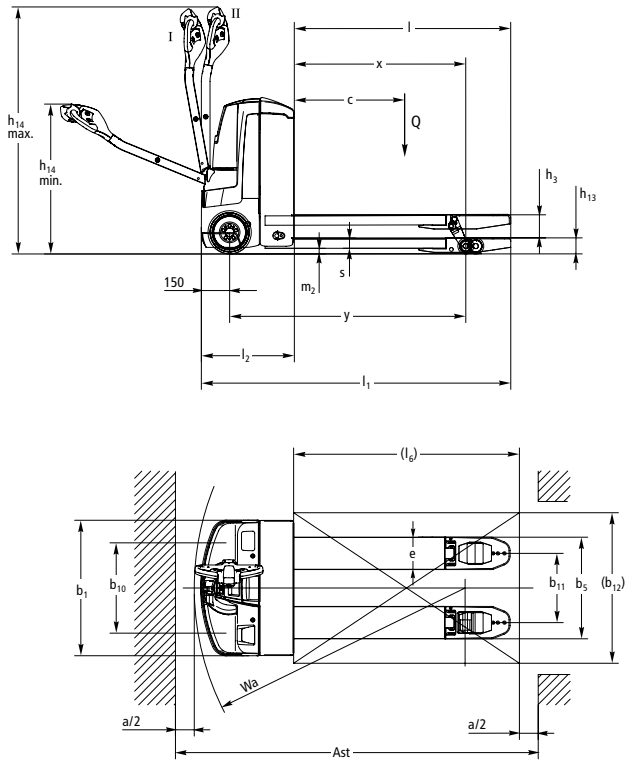

I = Travel range; II = Crawl speed range



Technical data in line with VDI 2198

			Jungheinrich			
			EJE 116	EJE 118	EJE 120	
Identification	1.1	Manufacturer (abbreviation)		Jungheinrich		
	1.2	Model				
	1.3	Drive		Electric		
	1.4	Manual, pedestrian, stand-on, seated, order picker operation		pedestrian		
	1.5	Load capacity/rated load	Q t	1.6	1.8	2
	1.6	Load centre distance	c mm	600		
	1.8	Load distance	x mm	911 ²⁾		
	1.9	Wheelbase	y mm	1,255 ¹⁾²⁾	1,255 ²⁾	1,255 ²⁾
	Weights	2.1.1	Net weight incl. battery (see row 6.5)	kg	439	441
2.2		Axle load with load front/rear	kg	737 / 1,302	787 / 1,302	809 / 1,632
2.3		Axle load without load front/rear	kg	346 / 93	347 / 94	397 / 94
Wheels / frame	3.1	Tyres		PU/PU		
	3.2	Tyre size, front	mm	Ø 230 x 70		
	3.3	Tyre size, rear	mm	Ø 85 x 110 / 85 x 85		
	3.4	Additional wheels (dimensions)	mm	Ø 100 x 40		
	3.5	Wheels, number front/rear (x = driven wheels)		1x +2/2 or 4		
	3.6	Tread width, front	b ₁₀ mm	508		
	3.7	Tread width, rear	b ₁₁ mm	368		
Basic dimensions	4.4	Lift	h ₃ mm	122		
	4.9	Height of tiller in drive position min. / max.	h ₁₄ mm	797 / 1,313		
	4.15	Height, lowered	h ₁₃ mm	85		
	4.19	Overall length	l ₁ mm	1,644 ¹⁾		
	4.20	Length to face of forks	l ₂ mm	494 ¹⁾		
	4.21	Overall width	b ₁ /b ₂ mm	720		
	4.22	Fork dimensions	s/e/l mm	55 / 172 / 1,150		
	4.25	Width across forks	b ₅ mm	540		
	4.32	Ground clearance, centre of wheelbase	m ₂ mm	30		
	4.33	Aisle width for pallets 1000 x 1200 sideways	Ast mm	1,879 ¹⁾		
4.34	Aisle width for pallets 800 x 1200 lengthways	Ast mm	1,929 ¹⁾	1,929 / 2,000 ¹⁾	1,929 ¹⁾	
4.35	Turning radius	W _a mm	1,440 ¹⁾			
Performance data	5.1	Travel speed, laden/unladen	km/h	6 / 6		
	5.2	Lift speed, laden/unladen	m/s	0.04 / 0.05		
	5.3	Lowering speed, laden/unladen	m/s	0.05 / 0.05		
	5.8	Max. gradeability, laden/unladen	%	10 / 20	9 / 20	8 / 20
	5.10	Service brake		electric		
Electrics	6.1	Drive motor, output S2 60 min.	kW	1.0		
	6.2	Lift motor rating at S3 10%	kW	1.2		
	6.3	Battery as per DIN 43531 /35/36 A, B, C, no		nein/B		
	6.4	Battery voltage/nominal capacity K5	V/Ah	24 / 150		
	6.5	Battery weight	kg	151		
	6.6	Energy consumption according to VDI cycle	kWh/h	0.36	0.4	0.44
Misc.	8.1	Type of drive control		AC SpeedControl		
	8.4	Sound pressure level at operator's ear as per EN 12053	dB (A)	70		

¹⁾ Battery compartment M (250 Ah): + 71 mm

²⁾ Load section lowered: + 53 mm

Benefit from the advantages



Powerful due to innovative 3-phase AC technology



Combined discharge indicator with state of charge display



Ergonomic tiller head

Innovative 3-phase AC technology

Jungheinrich three-phase AC motors offer higher performance while simultaneously reducing running costs:

- High level of efficiency with excellent energy management.
- Powerful acceleration.
- Quick change in direction of travel without 'having to think'.
- No carbon brushes - maintenance-free drive motor.
- Two-year warranty on the drive motor.

Long operating times

The energy-saving 3-phase AC technology in combination with battery capacities of up to 250 Ah are the best guarantee for long operating times:

- Battery compartment size S: 2 PzB 130/150 Ah
- Battery compartment size M: 2 PzS 180/250 Ah; also available as an option with lateral battery exchange on EJE 118/120
- Built-in charger (24 V/30 A for wet cell batteries and maintenance-free batteries) for easy charging at any mains socket (optional)

Fully informed at all times

Extensive instrument display and setting options enable the operator to monitor the situation at a glance:

- Combined battery discharge indicator (3-colour LCD) with lift cut-off and charge status indicator (for built-in charger).
- CanDis information display (optional) with additional hour-meter and error code logging.
- Activation of truck via PIN and selection of 3 travel programs via CanCode (optional).
- Adjustable travel parameters via CanDis and CanCode (optional).

Optimum cornering

Sprung and cushioned support wheels – linked via the ProTracLink torsion bar – distribute equalising forces dependent on travel conditions i.e. evenly across all wheels during straight-line travel; concentrated on the outer support wheel during cornering.

Ergonomic operation

The redeveloped tiller head is perfectly adjusted to operator requirements:

- Clear colour coded system and keys with sunken/ raised sections allowing intuitive operation.
- Handle position adjusted to suit natural operation.
- Crawl speed button on the underside of the tiller head for quick access and easy operation with the tiller in the vertical position.

- The tiller head also has excellent protection against breakdown with a contactless sensor system which has IP 65 protection against water ingress.
- Rocker switch for smooth operation in any tiller position.

Reduced maintenance

3-phase AC technology ensures significant long-term reduction in operating costs:

- Maintenance-free 3-phase AC drive motor with no carbon brushes.
- Easy access to all components through one-piece front cover located by only two screws.
- Secure protection from dust and damp due to enclosed controls and plugs according to IP 54.
- ProTracLink also ensures low support wheel damage during ramp work due to its self levelling adjustment. A torsion bar constantly keeps both support wheels at the same height reducing the chance of catching or damage to the lower support wheel.

Additional equipment

- Buzzer instead of horn.
- Special switch for easy release of brake.
- Vertical load guard.
- Cold store design.

Jungheinrich UK Ltd.

Head Office:
Sherbourne House
Sherbourne Drive
Tilbrook
Milton Keynes MK7 8HX
Telephone 01908 363100
Fax 01908 363180

info@jungheinrich.co.uk
www.jungheinrich.co.uk

The German production facilities in Norderstedt, Moosburg and Landsberg are certified. **ISO 9001**
ISO 14001

Jungheinrich fork lift trucks meet European safety requirements.



JUNGHEINRICH
Machines. Ideas. Solutions.